

**ELECTRIC VEHICLE CHARGING STATION PROGRAM  
GRANT AGREEMENT**

**between**

**The Santa Barbara County Air Pollution Control District**

**and**

**the City of Buellton, California**

**(Grant EVCS 002)**

This Grant Agreement, hereinafter referred to as "Agreement", is made this 18 day of October 20<sup>12</sup>, between the Santa Barbara County Air Pollution Control District, hereinafter referred to as "DISTRICT," and the City of Buellton, California, hereinafter referred to as "GRANTEE".

**RECITALS**

WHEREAS, the DISTRICT is a county air pollution control agency with the primary responsibility for preparing and implementing the Clean Air Plan to achieve and maintain state and federal air quality standards in the County of Santa Barbara as mandated by the California Clean Air Act and Federal Clean Air Act;

WHEREAS, Santa Barbara County does not meet state health-based air quality standards for ozone and particulate matter ("PM<sub>10</sub>"); and

WHEREAS, oxides of nitrogen and reactive organic gases are precursors to the formation of ozone, and the internal combustion engines used in motor vehicles is one of the main sources of these air pollutants in Santa Barbara County; and

WHEREAS, electric vehicles have no tailpipe emissions and Santa Barbara County is one of the top early adopter markets for electric vehicles in Southern California; and

WHEREAS, the DISTRICT has mitigation funds and wishes to utilize a portion of these funds for an Electric Vehicle Charging Station Infrastructure Program approved by the Board; and

WHEREAS, the DISTRICT is interested in encouraging the purchase and installation of electric vehicle charging stations under grant agreements with public entities; and

WHEREAS, GRANTEE has submitted a proposal which meet the requirements of the DISTRICT'S Electric Vehicle Charging Station Program and therefore, becomes eligible to receive funds from the DISTRICT; and

WHEREAS, GRANTEE represents it is highly qualified and experienced in its professional field, is able to perform the activities described in the STATEMENT OF GRANT OBLIGATIONS attached to this Agreement as Attachment A, and will not commence these activities until this Agreement is fully executed; and

WHEREAS, the DISTRICT has reviewed and decided to fund GRANTEE's proposal at an amount determined by the Air Pollution Control Officer; and

WHEREAS, the District Board of Directors has delegated authority to the Control Officer to execute certain grant agreements and this Agreement falls within that delegation authority.

NOW, THEREFORE, in consideration of the mutual promises and conditions listed below, it is hereby agreed between the DISTRICT and GRANTEE as follows:

## **GRANT TERMS AND CONDITIONS**

### **1. Obligations to be Performed Under this Agreement.**

Within the time specified in paragraph 2 (Time of Performance), GRANTEE shall perform all of the obligations described in this Agreement and set forth in the STATEMENT OF GRANT OBLIGATIONS, which is attached hereto as Attachment A and incorporated herein by this reference.

GRANTEE agrees to furnish all labor, materials, equipment, required licenses, permits, fees, and other appropriate legal authorization from all applicable federal, state, and local jurisdictions necessary to perform and complete, per schedule, in a professional manner, the obligations described herein.

### **2. Time of Performance.**

This Agreement shall commence on the date of signing by the GRANTEE and the DISTRICT (either the Board of Directors or the Control Officer).

GRANTEE shall have completed the tasks described in Attachment A (Statement Of Grant Obligations), on or before October 31, 2012. This time for completion may be extended, in writing, by the Control Officer for good cause. Operation shall commence upon completion of installation and shall continue for three (3) years.

### **3. Grant Funding.**

DISTRICT hereby agrees to provide funds to GRANTEE in the amount not to exceed \$19,726.05 toward the cost of completing the tasks described in Attachment A.. GRANTEE shall invoice the DISTRICT in accordance Attachment B (Grant Invoice Payment). GRANTEE shall provide DISTRICT any information necessary to verify the accuracy of the invoice. The DISTRICT will pay GRANTEE within thirty days of receipt of GRANTEE's invoice. All invoices or other payment documents must include the assigned DISTRICT contract number. Failure to properly reference this contract number may result in a delay of payment.

4. Matching Funds.

GRANTEE shall provide matching funds, as described in Attachment A (Statement Of Grant Obligations), as a condition of receiving this grant from the DISTRICT. Failure to provide such funds shall be, at the discretion of the Control Officer, grounds for termination of this Agreement. Upon such termination, GRANTEE shall within 14 days of termination, return any grant funds received from the DISTRICT under this Agreement. The Control Officer may waive the requirement for matching funds.

5. Non-Partnership.

This Agreement is not intended by the parties to constitute or create a joint venture, pooling arrangement, or formal business organization of any kind. The rights and obligations of the parties shall be only those expressly set forth herein.

6. Status of GRANTEE.

GRANTEE and GRANTEE's subcontractors shall perform all services under this Agreement as independent contractors and not as employees, officers or agents of DISTRICT or the County of Santa Barbara.

7. Records.

GRANTEE shall keep and provide to DISTRICT or its agents upon request, accurate financial records (including invoices and published price lists on which this Agreement was based) necessary to enable DISTRICT to review GRANTEE's performance of this Agreement. These records shall demonstrate the grant funding has been used for the completion of the tasks described in Attachment A. GRANTEE shall maintain all such records for at least three years after the termination of this Agreement.

8. Grant Reporting.

GRANTEE shall submit report(s) to the DISTRICT in accordance with the schedule and format specified in Attachment C (Grant Narrative Reports Format). Should GRANTEE fail to submit these reports to the DISTRICT, GRANTEE shall make the Electric Vehicle Charging station or any Electric Vehicle Charging Station installation supplies funded by this Agreement available for on-site monitoring by the DISTRICT for the term of the Agreement. Such onsite monitoring shall not relieve GRANTEE of its obligation to submit all required reports.

9. Audit and Review.

DISTRICT or its agents shall have the right to audit and review the records identified in Paragraph 7 (Records), above, maintained by GRANTEE pursuant to the terms of this Agreement to the extent necessary to verify the grant has been used in accordance with the

terms of this Agreement. Any such audit and review will be conducted by DISTRICT or County of Santa Barbara auditors or, at GRANTEE's option and expense, by a mutually acceptable third party accounting firm.

10. Indemnification.

GRANTEE shall defend, indemnify and save harmless DISTRICT and the County of Santa Barbara (COUNTY), their officers, agents and employees from any and all claims, demands, damages, costs, expenses (including attorney's fees), judgments or liabilities arising out of this Agreement or occasioned by the performance or attempted performance of the provisions hereof; including, but not limited to, any act or omission to act on the part of the GRANTEE or his agents or employees or other independent contractors directly responsible to him; except those claims, demands, damages, costs, expenses (including attorney's fees), judgments or liabilities resulting solely from the negligence or willful misconduct of the DISTRICT.

11. Nondiscrimination Clause.

GRANTEE shall abide by the Unlawful Discrimination Ordinance, Article XIII of Chapter 2 of the Santa Barbara County Code, which is attached hereto as Attachment D (County Of Santa Barbara Unlawful Discrimination Ordinance) and incorporated herein by this reference.

12. Title to Electric Vehicle Charging Station and Installation Supplies.

Title to, and risk of loss, of any Electric Vehicle Charging Station or any Electric Vehicle Charging Station installation supplies funded by this Agreement shall at all times vest in and with GRANTEE. GRANTEE acknowledges that DISTRICT did not supply, design or manufacture any Electric Vehicle Charging Station or any Electric Vehicle Charging Station installation supplies funded by this Agreement. The Electric Vehicle Charging Station or any Electric Vehicle Charging Station installation supplies are commercially manufactured and sold by a manufacturer determined by GRANTEE. DISTRICT specifically disclaims all warranties, express and implied, including the implied warranties of merchantability and fitness for the intended purpose, as to the low emissions equipment, any test equipment, or the field tests. In no event shall DISTRICT be liable to GRANTEE or any third party for any direct, indirect, consequential, special, incidental, or punitive damages for the design, manufacture, operation, maintenance, performance, or demonstration of the low emissions equipment under any theory, including but not limited to, tort, contract, breach of warranty, or strict liability.

13. Rights to Emission Reductions.

GRANTEE affirmatively certifies to the DISTRICT that the project described in Attachment A (Statement of Grant Obligations) is not required by any local, state and/or federal rule, regulation or Memorandum of Understanding currently in effect. GRANTEE transfers and conveys to DISTRICT all rights and claim to ownership of the emission reductions achieved through the installation and operation of any Electric Vehicle Charging

Station or any Electric Vehicle Charging Station installation supplies funded by this Agreement. GRANTEE shall not use or attempt to use the emission reductions achieved by the project as emission reduction credits. GRANTEE hereby fully and completely relinquishes such rights for the useful life of the project .

14. Termination.

a) DISTRICT. DISTRICT may, in its sole discretion, terminate this Agreement for convenience by giving thirty (30) days prior written notice to GRANTEE. GRANTEE shall not incur any unnecessary expenses or costs which are reimbursable under this Agreement during this period except those absolutely necessary to close out all activities related to the Agreement. Any other charges incurred by GRANTEE during this period will not be compensated by DISTRICT unless approved in writing by the Control Officer.

The DISTRICT may also terminate this Agreement for cause should GRANTEE default in the performance of this Agreement or materially breach any of its provisions. Such termination shall be by written notice and shall be effective upon receipt by GRANTEE. The DISTRICT may seek whatever legal, equitable, and other remedies available under State law for the GRANTEE's failure to comply and fully perform under the Agreement.

b) GRANTEE. GRANTEE may terminate its obligation funded under this Agreement for good cause, provided that, if requested by the Control Officer, GRANTEE shall reimburse the DISTRICT for the Grant funding specified in Paragraph 3 (Grant Funding), as follows:

<u>Termination Date</u>	<u>Reimbursement Due to District</u>
Prior to Operation	100 percent of Grant Funding
Year 1 of Operation	100 percent of Grant Funding
Year 2 of Operation	60 percent of Grant Funding
Year 3 of Operation	20 percent of Grant Funding
After year 3 of Operation	0 percent of Grant Funding

The year of the operation shall be determined in reference to Paragraph 2 (Time of Performance). GRANTEE'S notice of termination shall be in writing and shall be effective upon completion of the terms of this paragraph. Such notice shall terminate GRANTEE's obligation under Paragraphs 1 (Obligations to be Performed Under this Agreement) and 2 (Time of Performance) of this Agreement.

15. Conflict of Interest.

GRANTEE understands and acknowledges that the funds awarded under this Grant Agreement may only be awarded to GRANTEE in compliance with the requirements of the California Political Reform Act ("PRA"), California Government Code Section 87100 *et seq.* GRANTEE understands and acknowledges that the PRA prohibits any public official from participating in any governmental decision in which the public official knows he or she has a financial interest.

For the purposes of this provision, a "public official" is any person employed in the Innovative Technology Program at DISTRICT or any other public official of the DISTRICT or County of Santa Barbara who participated in the negotiation or making of this Agreement.

For the purposes of this provision, "GRANTEE" includes GRANTEE and GRANTEE's subcontractors and employees, business associates and business partners (including all personnel named in GRANTEE'S Proposal) who will receive a financial benefit from this Grant Agreement.

GRANTEE represents and warrants that a "conflict of interest" did not exist during the process that led to the award of this Grant Agreement. A conflict of interest exists if any of the following are true:

- a) GRANTEE is a business entity in which a public official has a direct or indirect investment worth two thousand dollars (\$2,000) or more;
- b) GRANTEE has been a source of income, other than gifts and other than loans by a commercial lending institution in the regular course of business on terms available to the public without regard to official status, aggregating five hundred dollars (\$500) or more in value provided to, received by, or promised to a public official within 12 months prior to GRANTEE's submission of an application to the DISTRICT for this Grant award.
- c) GRANTEE is a business entity in which a public official is a director, officer, partner, trustee, employee, or holds any position of management;
- d) GRANTEE has been a donor of, or any intermediary or agent for a donor of, a gift or gifts aggregating three hundred forty dollars (\$340) or more in value provided or promised to a public official within 12 months prior to GRANTEE's submission of an application to the DISTRICT for this Grant award.

GRANTEE shall disclose any conflict of interest to DISTRICT in writing prior to execution of this Agreement. DISTRICT may, in its sole discretion, decline to award or may terminate the grant to GRANTEE if a conflict of interest existed prior to the full execution of this Agreement. Failure of GRANTEE to comply with this provision shall be a material breach of this Agreement and shall, at DISTRICT's discretion, result in a total forfeiture of all Grant funds received under this Grant Agreement. GRANTEE shall also be liable to DISTRICT for treble damages of the amount of the Grant and DISTRICT's reasonable attorney's fees in any litigation necessary to enforce this provision.

#### 16. Taxes.

GRANTEE shall be responsible for payment of all taxes due as a result of the Agreement. GRANTEE's Federal Tax Identification Number or Social Security Number shall be on file

with DISTRICT prior to payment of grant funds.

17. Project Logos.

At the option of the DISTRICT, GRANTEE shall allow the placement of a DISTRICT logo on project facilities or equipment. The placement design, style and color will be determined mutually by DISTRICT and GRANTEE.

18. Public Education.

GRANTEE, upon request of DISTRICT, will participate in and assist with a one day public education and demonstration concerning the GRANTEE's project. GRANTEE will allow reasonable access by DISTRICT and the public to project facilities and equipment during this demonstration.

19. Remedies Not Exclusive.

No remedy herein conferred upon or reserved to DISTRICT is intended to be exclusive of any other remedy or remedies, and each and every such remedy, to the extent permitted by law, shall be cumulative and in addition to any other remedy given hereunder or now or hereafter existing at law or in equity or otherwise.

20. Publication.

DISTRICT shall have the right of prior written approval of any document which shall be disseminated to the public by GRANTEE in which GRANTEE utilized information obtained from DISTRICT in connection with performance under this Grant Agreement.

Information, data, documents, or reports developed by GRANTEE for DISTRICT, pursuant to the Grant Agreement, shall be part of DISTRICT's public record. GRANTEE may use or publish, at its own expense, such information provided to DISTRICT. The following acknowledgment of support and disclaimer must appear in each document disseminated, whether copyrighted or not, and based upon the work performed under this Grant Agreement.

"This report was prepared as a result of work sponsored by the Santa Barbara County Air Pollution Control District (SBCAPCD). The opinions, findings, conclusions, and recommendations are those of the author and do not necessarily represent the views of SBCAPCD. SBCAPCD, its officers, employees, contractors, and subcontractors make no warranty, expressed or implied, and assume no legal liability for the information in this report. SBCAPCD has not approved or disapproved this report, nor has SBCAPCD passed upon the accuracy or adequacy of the information contained herein."

GRANTEE shall inform its officers, employees, and subcontractors involved in the performance of this Grant Agreement of the restrictions contained herein and require

compliance with the above publication terms.

21. Waivers.

The waiver by either party to this Agreement of any term, covenant, or condition of this Agreement or of any provision, ordinance, or law, shall not be deemed to be a continuing waiver of such term, covenant, condition, or law, or of any subsequent breach or violation of the same, or of any other term, covenant, ordinance of law.

22. Amendment.

This Agreement may only be amended in writing executed by the DISTRICT Board and GRANTEE or, where authorized by the Board, by the Control Officer and GRANTEE.

23. California Law to Apply.

This Agreement shall be construed under and in accordance with the laws of the State of California. All obligations created under this Agreement are performable in California.

24. Assignment.

This Agreement shall not be assigned by GRANTEE without the prior written consent of the Control Officer. In the event GRANTEE desires to sell, lease, or otherwise transfer any Electric Vehicle Charging Station or any Electric Vehicle Charging Station installation supplies funded by this Agreement, GRANTEE shall promptly notify DISTRICT and shall provide the potential buyer or other transferee with a copy of this Agreement. The buyer or other transferee must agree in writing to abide by the terms of this Agreement prior to GRANTEE closing any such sale, lease or other transfer.

25. Grant Agreement Integrated.

This Agreement represents the entire and integrated Agreement between DISTRICT and GRANTEE and supersedes any and all other negotiations, representations, and/or agreements, either oral or in writing, between the parties hereto with respect to the subject matter hereof, and no other agreement, statement or promise relating to the subject matter of this Agreement which is not contained herein shall be valid or binding.

26. Conflicts Between Grant Agreement and Incorporated Attachments.

With the exception of the County's Unlawful Discrimination Ordinance, to the extent that any provisions in any of the other attachment(s) which are incorporated into this Agreement by reference, conflict with any provision contained in this Agreement, the provision of this Agreement shall take precedence and govern.

27. Provisions Required by Law Deemed Inserted.

Each and every provision of law and clause required by law to be inserted in this Grant Agreement shall be read and enforced as though it were included herein, and if through mistake or otherwise any such provision is not inserted or is not correctly inserted, then upon application of either party, this Grant Agreement shall forthwith be physically amended to make such insertion or correction.

28. Unusual Circumstances.

The parties shall be excused from performing their respective obligations in the event they are prevented from performing so by reason of circumstances beyond their control, including, but not limited to, strikes and other labor disputes, wars, civil commotion, natural calamity, fire, equipment breakdown or failures. In the event of any delay described above, the time for performance may be extended by mutual agreement for a period equal to the length of the delay.

29. Point of Contact.

All notices referenced in this Agreement shall be in writing and shall be given by first class mail addressed as follows, or at such other address or to such person that the parties may from time to time designate in writing:

**GRANTEE**

City of Buellton  
Planning Department  
107 W. Highway 246  
P.O. Box 1819  
Buellton, CA 93427  
Attn: Angela Perez

**DISTRICT**

Santa Barbara County Air Pollution Control  
District  
260 North San Antonio Rd., Suite A  
Santa Barbara, California 93110  
Attn: Ron Tan

30. Equipment Maintenance.

GRANTEE will maintain and operate any Electric Vehicle Charging Station or any Electric Vehicle Charging Station installation supplies funded by this Agreement according to manufacturer's recommendations.

31. Equipment Operating Area.

GRANTEE shall operate any Electric Vehicle Charging Station or any Electric Vehicle Charging Station installation supplies funded by this Agreement within Santa Barbara County.

32. On-Site Inspections and Audits.

GRANTEE shall allow the DISTRICT or designee to inspect any Electric Vehicle Charging Station or any Electric Vehicle Charging Station installation supplies funded by this Agreement and associated records during the contract term. GRANTEE shall maintain and retain the project records for at least two years after contract expiration or three years after final project payment, whichever is later.

This Grant Agreement between Santa Barbara County Air Pollution Control District and the City of Buellton was executed in the County of Santa Barbara, State of California on the dates indicated below.

ATTEST:

Louis D. Van Mullem, Jr  
Clerk of the Board

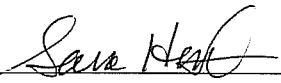
By   
Deputy

Santa Barbara County Air Pollution Control  
District, State of California

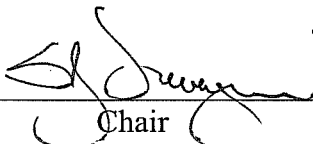
By   
Chair

Date: 10/13/12

City of Buellton, California

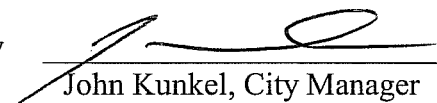
By   
John Kunkel, City Manager

Date: 9/28/12

APPROVED AS TO FORM:

RAY AROMATORIO, ARM, AIC  
Risk Manager

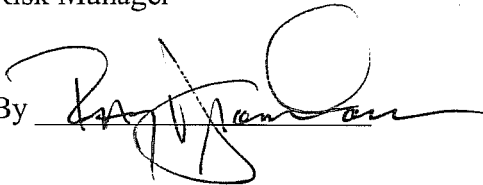
By 

APPROVED AS TO FORM

Dennis A. Marshall  
County Counsel

APPROVED AS TO FORM:

ROBERT W. GEIS, CPA  
Auditor Controller

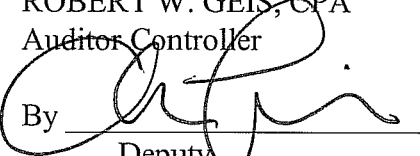
By   
Deputy

By   
Deputy

Deputy Auditor-Controller  
Gregory Eric Levin  
Advanced and Specialty Accounting

ATTACHMENT A  
STATEMENT OF GRANT OBLIGATIONS



# City of Buellton PLANNING DEPARTMENT

July 17, 2012

Ron Tan  
Santa Barbara County Air Pollution Control District  
260 North San Antonio Road, Suite A  
Santa Barbara, CA 93110-1315

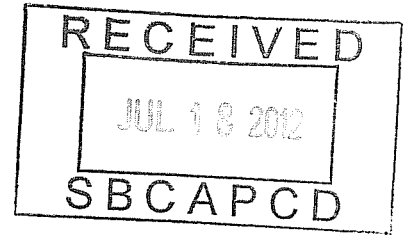

Re: Electric Vehicle Charging Station Grant

Dear Mr. Tan:

Enclosed is the City of Buellton's application for a grant for the purchase and installation of a dual electric vehicle charging station (EV Charging Station).

The City proposes to purchase a Level 2, Model CT2025, EV Charging Station made by Coulomb Technologies (see Attachment 1, Data Sheet). The EV Charging Station will consist of one pedestal with two chargers. The EV Charging Station will be located at the Santa Ynez Valley Marriott Hotel, 555 McMurray Road, Buellton (see Attachment 2, Vicinity Map).

We will need to install a new 40 amp circuit for each charge port. A new 200 amp panel and main breaker will be installed. Swotting, concrete removal, trenching, and concrete patching will be required to get circuits from the panel to the installation location.

It is anticipated that the installation will begin on August 14, 2012 and will take 2 days to complete. Estimated cost for both the installation and the EV Charging Station is \$19,726.05 (see Attachments 3 and 4, Estimates). The estimate for installation costs is included in Attachment 3. Attachment 3 also includes costs for an incorrect EV Charging Station. Attachment 4 includes the estimate for the cost of the EV Charging Station that the City is proposing to purchase.

The City is requesting a waiver from the requirement to have matching funds.

Please contact Angela Perez at (805) 688-7474 if you have any questions. Thanks.

Sincerely,

John Kunkel  
City Manager

Enclosures:

- EV Charging Station Grant Application
- Attachment 1, ChargePoint Networked Charging Stations Data Sheet
- Attachment 2, Vicinity Map
- Attachment 3, Estimate Dated June 19, 2012
- Attachment 4, Estimate Dated June 27, 2012

# Attachment 1



## ChargePoint Networked Charging Stations

### CT2020 FAMILY

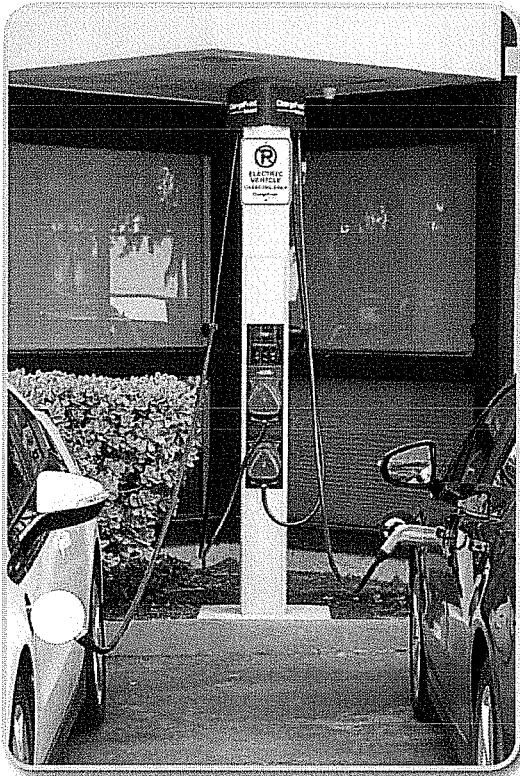

ChargePoint® Networked Charging Stations, by Coulomb Technologies, offer municipalities, corporations, fleets, and utilities, high-reliability, plug-in electric vehicle charging that drivers prefer. The easy-to-use stations provide multiple power options, integrating aesthetics and ergonomics with sturdy construction—ideal for residential, commercial and outdoor public applications.

The CT2020 dual charging stations provide two 7.2 kW (208/240 V @ 30 A) Level II charging ports and are designed for public outdoor applications for the North American marketplace. Charging is delivered via standard SAE J1772™ connectors attached to self-retracting<sup>1</sup> cords.

To enhance safety and eliminate energy theft, drivers access and energize the station using a ChargePass™ card or contactless credit card. The station's highly visible display guides drivers with instructive messages and can be used to display custom advertisement or greetings for drivers.

#### Software Application Services

Set pricing and collect fees, provide 24/7 driver assistance, control access, enable reservations, display advertisements, track usage, and monitor the station remotely using the growing suite of ChargePoint Network on-demand software applications and a web browser.

#### Utility Light<sup>1</sup>

Features an energy-efficient, photosensor-activated light to provide drivers with the visibility they need to start and stop charging sessions in areas with poor lighting conditions.

#### Hassle-Free Cord Management<sup>1</sup>

The CT2025's self-retracting cord management system eliminates the need for drivers to coil up the J1772™ cord and return it to its host hanger, ensuring that the cord is always off the ground when not in use.

#### Smart Card Reader

Provide optional driver billing and custom access control, preventing electricity theft and enhancing safety, with an integrated standards-based RFID reader that accepts ChargePass cards, contactless credit cards, and MIFARE-based transportation cards.

#### Intelligent Power Control

Ensure power is delivered only when a driver is authorized and the EV connector is properly inserted.

#### Vacuum Florescent Display with Multiple Language Support

Display instructive, advertisement, and greeting messages in many languages on the bright, easy-to-read display.

#### Integrated Fault Detection

- Ground Fault Detection: Integrated ground-fault detection circuitry with auto retry and driver notification.
- Over-Current Detection: Disconnects power to prevent nuisance breaker trips at service panel. Auto retry and driver notification.
- Plug-Out Detection: Algorithm disengages power and notifies the driver when a plug is removed.

#### Over-the-Air Station Upgrade

Keep charging station current with future and evolving EV needs by upgrading station firmware remotely over-the-air.

#### Utility Grade Energy Meter

Provide accurate bi-directional energy measurement with integrated power metering circuitry.

#### Remote Diagnostics and Control

Minimize the need for on-site maintenance with real-time remote alarm monitoring and control.

#### Network Interface

Wireless mesh and cellular network interfaces allow seamless integration with the ChargePoint Network and ChargePoint Network application services.

#### Smart Grid Compatible

Enable Time-Of-Use (TOU) pricing and demand response by integrating with Advanced Metering Infrastructures (AMIs).



Coulomb Technologies, Inc.  
1692 Dell Ave.  
Campbell, CA 95008-6901 USA  
US toll free: +1-877-370-3802  
www.coulombtech.com  
www.chargepoint.net

Listed by Underwriters Laboratories Inc. LISTED

<sup>1</sup>Included on the CT2025 only.

# Attachment 1



## CT2020 Family

### CT2021 - Mechanical Drawings

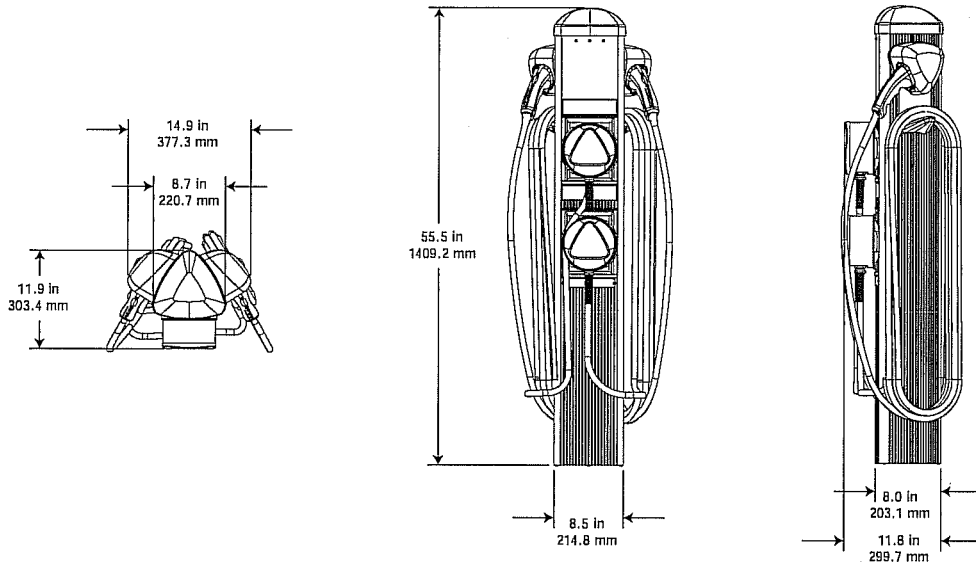

### CT2021 - Front

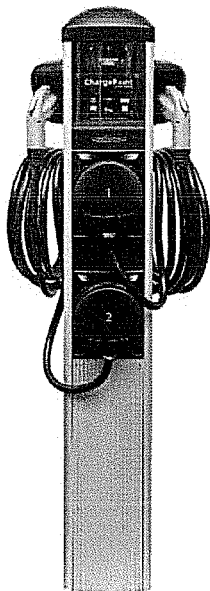

### CT2021 - Side

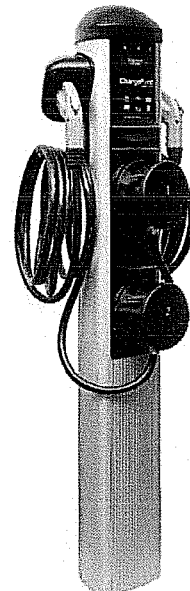

# Attachment 1



## Specifications CT2020 FAMILY

### Electrical Input

Input Power	7.2 kW (x 2)
Input Voltage	208/240 VAC
Input Current	30 A (x 2)
Input Power Connections	Line A1, Line A2, Earth, Line B1, Line B2 (two independent 40 A branch circuits, each providing Line 1 and Line 2, and a single protective Earth conductor)
Required Service Panel Breaker	40 A double pole breaker (non-GFCI type) on dedicated circuit (x 2)
Standby Power	7 W typical (not including LED light fixture)

### Electrical Output

Output Charging Power	7.2 kW (x 2)
Output Voltage	240 VAC (x 2)
Output Current	30 A (x 2)
Output Charging Connector	SAE J1772™ EV Connector on 18' (5.48 m) cord (x 2). On CT2025 only, cord is self-retracting.

### Functional Interfaces

Lighting <sup>1</sup>	Photosensor-activated 5 W LED light (equivalent to 40 W incandescent)
Card Reader	ISO 15693, 14443
Ground Fault Detection	20 mA CCID with auto retry (15 minute delay, 3 tries)
Plug-Out Detection	Power terminated per SAE J1772™ specification
Power Measurement	2% @ 15 minute intervals
Local Area Network	2.4 GHz 802.15.4 dynamic mesh network
Wide Area Network	Commercial GPRS or CDMA cellular data network

### Safety and Operational Ratings

Safety Compliance	UL Listed for USA and cUL certified for Canada; Complies with UL 2594, UL 2231-1, UL 2231-2, UL 1998, UL 991, NEC Article 625
Surge Protection	6 kV @ 3,000. In geographic areas subject to frequent thunderstorms, supplemental surge protection is recommended.
EMC Compliance	FCC Part 15 Class A
Operating Temperature	-22° F to 122° F (-30° C to +50° C)
Operating Humidity	95% non-condensing
Enclosure	Type 3R
Terminal Block Temperature Rating	100° C (212° F)
Maximum Charging Stations per 802.15.4 Radio Group	24. Each station must be within 150 feet "line of sight" of at least one other station.
Wind Loading	Up to 150 mph (241 kph). On the CT2025, includes a 12" x 18" (30 cm x 46 cm) additional signage area.
Approximate Shipping Weights	CT2021: 98 lbs (44.5 kg) CT2025: 140 lbs (63.5 kg)

<sup>1</sup>Included on the CT2025 only.

Coulomb Technologies, Inc. reserves the right to alter product offerings and specifications at any time without notice, and is not responsible for typographical or graphical errors that may appear in this document.

# Attachment 1



## CT2020 Family

### CT2025 - Mechanical Drawings

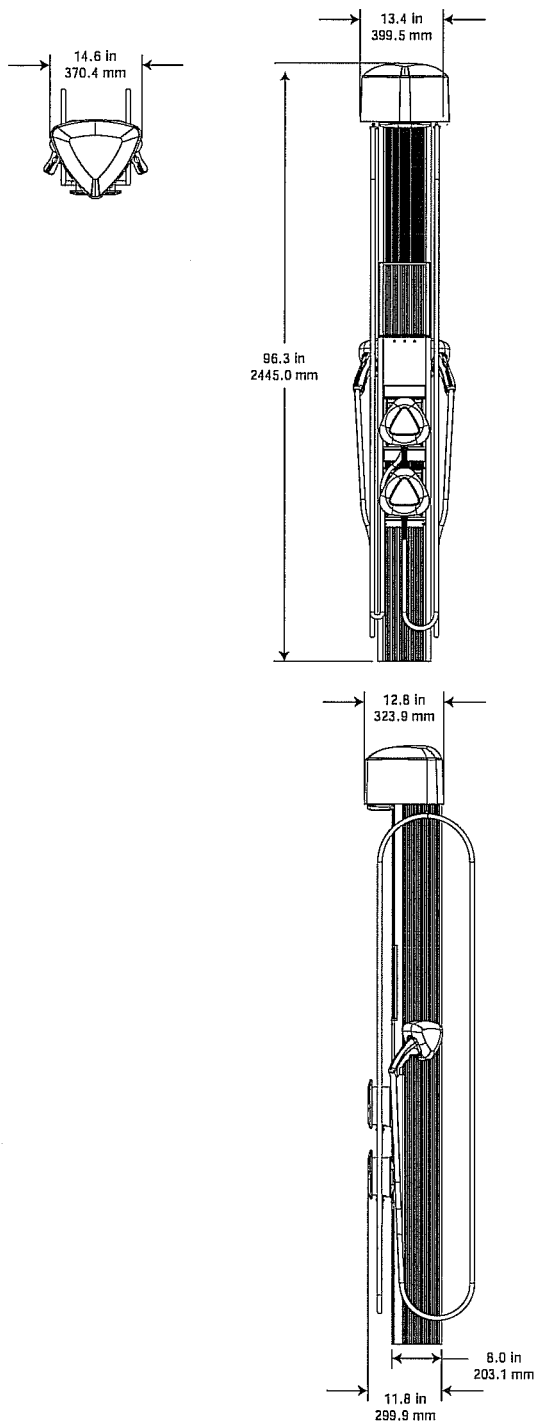

### Ordering Information

Specify model number followed by the applicable code(s). The order code sequence is:

#### Model-Modem-SIM-Card Reader-Warranty

Option	Order Code
<i>Model</i>	
Standard Bollard Mount	CT2021
Bollard Mount with Top Lamp and Cable Retractors	CT2025
<i>Modem</i>	
Integral GPRS ChargePoint Gateway Modem	-GPRS
Integral CDMA ChargePoint Gateway Modem	-CDMA
<i>SIM</i>	
USA GPRS SIM	-SIM1
Canada GPRS SIM	-SIM2
<i>Card Reader</i>	
Contactless Credit Card Reader	-CCR
<i>Warranty</i>	
5 Year Parts Only Extended Warranty	-EW5
5 Year Parts Only Extended Warranty - Gateway	-EW5GW

### Order Code Examples

If ordering this	The order code would be
Standard Bollard Mount with GPRS Modem	CT2021-GPRS
Bollard Mount with Top Lamp and Cable Retractors, GPRS Modem, Canada GPRS SIM	CT2025-GPRS-SIM2
Standard Bollard Mount with USA GPRS Modem, Contactless Credit Card Reader, and 5 Year Warranty	CT2021-GPRS-SIM1-CCR-EW5GW

For pricing and additional product information, contact the distributor in your area.  
For a complete list of distributors, go to [www.coulombtech.com](http://www.coulombtech.com) and click Purchase.

Coulomb Technologies, Inc. - 1692 Dell Ave. - Campbell, CA 95008-6901 USA  
408.841.4500 - 877.370.3802 - [info@coulombtech.com](mailto:info@coulombtech.com)  
[www.coulombtech.com](http://www.coulombtech.com) - [www.chargepoint.net](http://www.chargepoint.net)



# Attachment 2: Vicinity Map

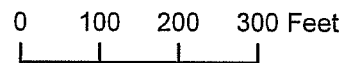

# Attachment 3

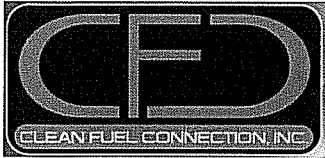

127 La Porte Street, Unit M  
Arcadia, CA 91006

## Estimate

Date	Estimate #
6/19/2012	1567

Name / Address
City of Buellton Angela Perez P.O. Box 1819 Buellton, CA 93427

Ship To
City of Buellton Angela Perez P.O. Box 1819 Buellton, CA 93427

Project	Job Name	P.O. No.
	Buellton Marriot	

Description	Qty	Rate	Total
Coulomb Installation: Install and wire 2 Coulomb CT2021 dual port Level 2 electric vehicle chargers. Installation includes a new 40 amp circuit for each charge port. A new 200 amp weather proof outdoor panel and main breaker will be installed to feed the chargers. Swotting, concrete removal, trenching and concrete patching will be required to get circuits from the panel to the installation location. Permitting is included.	1	11,125.00	11,125.00
Installation Breakdown			
Install a new 200 amp weatherproof single phase commercial electrical panel with main breaker. Panel to fed from existing main service panel 400 amp fused disconnect. New breakers will be installed in the panel to feed the chargers.	0	3,300.00	0.00
Run 2" conduit with weatherproof fittings from new panel through equipment enclosure to block wall, Penetrate block wall and continue conduit run through trench to inground junction boxes adjacent to EVSE locations.	0	2,300.00	0.00
Concrete and underground work: Cut concrete sidewalk and remove, core wall for conduit, trenching for underground conduit runs, re-pour sidewalks and concrete bases for chargers, compact and backfill trenches.	0	3,375.00	0.00
Coulomb Installation: Install and wire EVSE's	0	1,525.00	0.00
Permits and Engineering	0	625.00	0.00
<del>CT2101 GPRS-SIM1 LOCK</del>	1	<del>4,860.00</del>	<del>4,860.00</del>

*Correct charger costs are on Attachment 4*

Credit card payment of customer balance is due upon completion of installation.  Quote expires in 30 days	<b>Subtotal</b>
	<b>Sales Tax (0.0%)</b>
	<b>Total</b>

<b>Acceptance of Quote &amp; Payment Terms</b>	Customer's Signature	Date

# Attachment 3



127 La Porte Street, Unit M  
Arcadia, CA 91006

## Estimate

Date	Estimate #
6/19/2012	1567

Name / Address
City of Buellton Angela Perez P.O. Box 1819 Buellton, CA 93427

Ship To
City of Buellton Angela Perez P.O. Box 1819 Buellton, CA 93427

Project	Job Name	P.O. No.
	Buellton Marriot	

Description	Qty	Rate	Total
<del>1 Year Commercial ChargePoint Network Service Plan Per L2 Port</del>	<del>2</del>	<del>216.00</del>	<del>432.00</del>
<del>Commissioning</del>	<del>2</del>	<del>0.00</del>	<del>0.00</del>
<del>Estimated Shipping</del>	<del>4</del>	<del>100.00</del>	<del>400.00</del>

**Credit card payment of customer balance is due upon completion of installation.**

Quote expires in 30 days

**Subtotal** \$16,817.00

**Sales Tax (0.0%)** \$0.00

**Total** \$16,817.00

**Acceptance of Quote & Payment Terms**

Customer's Signature

Date

# Attachment 4



127 La Porte Street, Unit M  
Arcadia, CA 91006

## Estimate

Date	Estimate #
6/27/2012	1591

Name / Address
City of Buellton Angela Perez P.O. Box 1819 Buellton, CA 93427

Ship To
City of Buellton Angela Perez P.O. Box 1819 Buellton, CA 93427

Project	Job Name	P.O. No.

Description	Qty	Rate	Total
CT2025-GPRS-SIM1-LOCK-CCR	1	7,986.55	7,986.55T
1 Year Commercial ChargePoint Network Service Plan Per L2 Port	1	214.50	214.50T
Commissioning	1	200.00	200.00
Shipping (7 boxes)	1	200.00	200.00

Credit card payment of customer balance is due upon completion of installation.  Quote expires in 30 days	<b>Subtotal</b>	\$8,601.05
	<b>Sales Tax (0.0%)</b>	\$0.00
	<b>Total</b>	\$8,601.05

<b>Acceptance of Quote &amp; Payment Terms</b>		
	Customer's Signature	Date

ATTACHMENT B  
GRANT INVOICE PAYMENT

GRANTEE shall invoice the DISTRICT as follows:

- Not-to-exceed (NTE) total of \$19,726.05 upon completion of all the grant obligations, as specified above in Attachment A (Statement of Grant Obligations), and itemized as follows :
  - ❖ Purchase and installation of two Coulomb Level 2 charging stations as detailed in Attachment A.
- Attach a copy of vendors' invoice to GRANTEE for the Electric Vehicle Charging Station (include model number, model year) and/or itemized breakdown of all supplies used for the installation of Electric Vehicle Charging Station(s).

ATTACHMENT C  
GRANT NARRATIVE REPORTS FORMAT

GRANTEE shall submit an annual narrative report to the District after the first year of operation of the Electric Vehicle Charging Station. . The purpose of these reports is to provide the DISTRICT with feedback as to GRANTEE's experience with the Electric Vehicle Charging Station Charging Station. The reports shall include the following items:

1. Name, address, and telephone of GRANTEE;
2. Make and model and location of equipment purchased;
3. Operating hours for the Electric Vehicle Charging Station for the most recent 12 months of operation;
4. Discussion of condition of equipment including any repairs, problems, or benefit with the Electric Vehicle Charging Station.
5. Any conditions (e.g., weather) that significantly affected the annual usage of the Electric Vehicle Charging Station from routine service.

ATTACHMENT D  
COUNTY OF SANTA BARBARA UNLAWFUL DISCRIMINATION ORDINANCE

Sec. 2-95. Prohibition of unlawful discrimination in employment practices. The County of Santa Barbara reserves the right to terminate forthwith each and every written contract and agreement (except purchase orders) for goods and/or services entered into by the County of Santa Barbara or by its joint powers, agencies or agents with the consent of the other parties (hereinafter called "contractor") including but not limited to concessions, franchises, construction agreements, leases, whether now in effect or hereinafter made if the county finds that the contractor is discriminating or has discriminated against any employee or applicant for employment in violation of any applicable state or federal laws, rules or regulations which may now or hereafter specifically prohibit such discrimination on such grounds as race, religion, sex, color, national origin, physical handicap when otherwise qualified, Vietnam era veteran/disabled, or age.

Such finding may only be made after contractor has had a full and fair hearing on notice of thirty (30) days before an impartial hearing officer at which hearing contractor may introduce evidence, produce witnesses and have the opportunity to cross-examine witnesses produced by the county. Further, any finding of discrimination must be fully supported by the facts developed at such hearing and set forth in a written opinion; and in addition, contractor may move in the appropriate court of law for damages and/or to compel specific performance of a contractor or agreement if any the above procedures are not afforded to the contractor. If contractor is not found to have engaged in unlawful discriminatory practices, county shall pay all costs and expense of such hearing, including reasonable attorneys' fees to contractor in accordance with current Santa Barbara County Superior Court schedule of attorneys' fees for civil trials. If contractor is found to have engaged in such unlawful discriminatory employment practices, contractor shall pay all such costs, expenses and attorneys' fees.

Whether or not a contract or agreement is still in existence at the time of final determination of such unlawful discrimination, the contractor shall forthwith reimburse county for all damages directly stemming from such discrimination; however, those damages shall not exceed and are not reimbursable in an amount which exceeds amounts paid contractor under the terms of the contract or agreement.

Nothing in this section 2-95 shall directly or by interpretation give a private cause of action to any third party (not a signatory to the contract or agreement) including employees past or present, or applicants for employment to contractor, it being the sole purpose of this clause to administratively assure compliance with the nondiscrimination clauses contained herein.

Employment practices shall include, but are not limited to employment, promotion, demotion, transfer, recruitment and advertising for recruitment, layoff or other termination, rate of pay, employee benefits and all other forms of compensation selection for training and apprenticeship and probationary periods.

Contractor shall permit access at all reasonable time and places to all of its records of employment, advertising, application forms, tests and all other pertinent employment data and

records, to the County of Santa Barbara, its officers, employees and agents for the purpose of investigation to ascertain if any unlawful discrimination as described herein has occurred or is being practiced, provided that such records are relevant to a complaint of an unlawful discriminatory practice which has been forwarded to contractor reasonably prior to the time contractor is asked to make such records available. In addition, all such records shall be deemed "Confidential" by the officers, employees and agent of the county. No records or copies of such records may be removed from the premises of contractor and no disclosure, oral or written of such record, may be made to third parties except as provided within the agreement.

Provided, however, that in the event of a hearing to determine whether or not contractor is engaging in unlawful discrimination in employment practices as defined herein, the board of supervisors of Santa Barbara County may issue subpoenas to require that certified copies of such records be made available to the hearing.

Failure to fully comply with any of the foregoing provisions relating to unlawful discrimination in employment practices shall be deemed to be a material breach of any contract or agreement with the County of Santa Barbara. All persons contracting with or who have contracts for goods or services with the county shall be notified that this chapter applies to their contract or agreement with the County of Santa Barbara. (Ord. No. 2946, SS 1; Ord. No. 2993, SS 1; Ord. No. 3018, SS 1)

Sec. 2-95.5. Exceptions. Notwithstanding any other provisions in this article, any party contracting with the County of Santa Barbara having an affirmative action program which has been approved within thirty-six (36) months from the date of the contract by an agency of the federal government shall be deemed to be in compliance with the provisions of this article upon furnishing documentary evidence of such approval satisfactory to the county affirmative action officer. Loss of such approval shall be immediately reported by such party to the county affirmative action officer.

Sec. 2-96. Purchase orders. Purchase orders shall contain the following clause as grounds for termination of such purchase order.

"If complaint is made that seller is engaging in discriminatory employment practices made unlawful by applicable state and federal laws, rules or regulations, and the State Fair Employment Practice Commission or the Federal Equal Employment Opportunities Commission determines that such unlawful discrimination exists, then the County of Santa Barbara may forthwith terminate this order." (Ord. No. 2946, § 1)

Sec. 2-97. Affirmative action officer. At the discretion of the county affirmative action officer, he or she shall promptly and thoroughly investigate, or cause to be investigated reports and complaints from whatever source, that any party contracting with the County of Santa Barbara is engaging, or during the term of a contract or agreement with the County of Santa Barbara has engaged, in any unlawful discriminatory employment practices as described in Section 2-95 of this Code. If the investigation discloses reason to believe such unlawful discrimination does exist or has existed and the conditions giving rise thereto have not been changed so as to prevent further

such unlawful discrimination, and the said party shall not forthwith terminate such unlawful discrimination, take all appropriate steps to prevent a recurrence of such or other unlawful practices, and compensate the person or persons unlawfully discriminated against for any and all loss incurred by reason of such unlawful discrimination, all to the satisfaction of the affirmative action officer, then the affirmative action officer shall cause the matter to be presented for action to the State Fair Employment Practices Commission or the Federal Equal Employment Opportunities Commission, or both, and to any other concerned state or federal agencies or officers.

If and when it has been finally determined by the affirmative action officer, county counsel, or state or federal regulatory agencies that such unlawful discriminatory employment practice has in fact so occurred or are being carried on, then the affirmative action officer shall forthwith present the entire matter to the board of supervisors of the county, together with all damages, costs and expense related thereto and incurred by county, for appropriate action by the board of supervisors in accord with the intent and purposes of this article and of the affirmative action program of the County of Santa Barbara (Ord. No. 2946, § 1).

ATTACHMENT E  
STANDARD INDEMNIFICATION AND INSURANCE PROVISIONS

INDEMNIFICATION

GRANTEE shall defend, indemnify and save harmless DISTRICT and the County of Santa Barbara (COUNTY), their officers, agents and employees from any and all claims, demands, damages, costs, expenses (including attorney's fees), judgments or liabilities arising out of this Agreement or occasioned by the performance or attempted performance of the provisions hereof; including, but not limited to, any act or omission to act on the part of the GRANTEE or his agents or employees or other independent contractors directly responsible to him; except those claims, demands, damages, costs, expenses (including attorney's fees), judgments or liabilities resulting from the sole negligence or willful misconduct of the DISTRICT.

GRANTEE shall notify DISTRICT immediately in the event of any accident or injury arising out of or in connection with this Agreement.

INSURANCE

Without limiting the GRANTEE's indemnification of DISTRICT and the COUNTY, GRANTEE shall procure the following required insurance coverages at its sole cost and expense. All insurance coverages are to be placed with insurers which (1) have a Best's rating of no less than A: VII, and (2) are admitted insurance companies in the State of California. All other insurers require the prior approval of DISTRICT. Such insurance coverage shall be maintained during the term of this Agreement. Failure to comply with the insurance requirements shall place GRANTEE in default. Upon request by DISTRICT, GRANTEE shall provide a certified copy of any insurance policy to DISTRICT within ten (10) working days.

1. Workers' Compensation Insurance: Statutory Workers' Compensation and Employers Liability Insurance shall cover all GRANTEE's staff while performing any work incidental to the performance of this Agreement. The policy shall provide that no cancellation, or expiration or reduction of coverage shall be effective or occur until at least thirty (30) days after receipt of such notice by DISTRICT. In the event GRANTEE is self-insured, it shall furnish to DISTRICT a copy of Certificate of Consent to Self-Insure issued by the Department of Industrial Relations for the State of California. This provision does not apply if GRANTEE has no employees as defined in Labor Code Section 3350 et seq. during the entire period of this Agreement and GRANTEE submits a written statement to DISTRICT stating that fact.
2. General and Automobile Liability Insurance: The general liability insurance shall include bodily injury, property damage and personal injury liability coverage, shall afford coverage for all premises, operations, products and completed operations of GRANTEE and shall include contractual liability coverage sufficiently broad so as to include the insurable liability assumed

by the GRANTEE in the indemnity and save harmless provisions [above] of the Indemnification Section of this Agreement between DISTRICT and GRANTEE. The automobile liability insurance shall cover all owned, non-owned and hired motor vehicles that are operated on behalf of GRANTEE pursuant to GRANTEE's activities hereunder. GRANTEE shall require all subcontractors to be included under its policies or furnish separate certificates and endorsements to meet the standards of these provisions by each subcontractor. DISTRICT and the COUNTY, their officers, agents, and employees shall be Additional Insured status on any policy. A cross liability clause, or equivalent wording, stating that coverage will apply separately to each named or additional insured as if separate policies had been issued to each shall be included in the policies. A copy of the endorsement evidencing that the policy has been changed to reflect the Additional Insured status must be attached to the certificate of insurance. The limit of liability of said policy or policies for general and automobile liability insurance shall not be less than \$1,000,000 per occurrence and \$2,000,000 in the aggregate. Any deductible or Self-Insured Retention {SIR} over \$10,000 requires approval by DISTRICT.

Said policy or policies shall include severability of interest or cross liability clause or equivalent wording. Said policy or policies shall contain a provision of the following form:

*"Such insurance as is afforded by this policy shall be primary and if the COUNTY has other valid and collectible insurance, that other insurance shall be excess and non-contributory."*

If the policy providing liability coverage is on a 'claims-made' form, the GRANTEE is required to maintain such coverage for a minimum of three years following completion of the performance or attempted performance of the provisions of this agreement. Said policy or policies shall provide that DISTRICT shall be given thirty (30) days written notice prior to cancellation or expiration of the policy or reduction in coverage.

GRANTEE shall submit to the office of the designated DISTRICT representative certificate(s) of insurance documenting the required insurance as specified above prior to this Agreement becoming effective. DISTRICT shall maintain current certificate(s) of insurance at all times in the office of the designated DISTRICT representative as a condition precedent to any payment under this Agreement. Approval of insurance by DISTRICT or acceptance of the certificate of insurance by DISTRICT shall not relieve or decrease the extent to which the GRANTEE may be held responsible for payment of damages resulting from GRANTEE's services or operations pursuant to the contract, nor shall it be deemed a waiver of DISTRICT rights to insurance coverage hereunder.

In the event the GRANTEE is not able to comply with DISTRICT's insurance requirements, DISTRICT may, at its sole discretion and at the GRANTEE's expense, provide compliant coverage.

The above insurance requirements are subject to periodic review by DISTRICT and the COUNTY. The COUNTY's Risk Manager is authorized to change the above insurance requirements, with the

concurrence of County Counsel, to include additional types of insurance coverage or higher coverage limits, provided that such change is reasonable based on changed risk of loss or in light of past claims against DISTRICT and the COUNTY or inflation. This option may be exercised during any amendment of this Agreement that results in an increase in the nature of DISTRICT's or the COUNTY's risk and such change of provisions will be in effect for the term of the amended Agreement. Such change pertaining to types of insurance coverage or higher coverage limits must be made by written amendment to this Agreement. GRANTEE agrees to execute any such amendment within thirty (30) days of acceptance of the amendment or modification.

In the alternative to the foregoing insurance requirements, DISTRICT and COUNTY acknowledge that GRANTEE is a California Municipal Corporation within the jurisdiction of COUNTY and possesses insurance, self-insurance and excess-coverage insurance as referenced in this Agreement far in excess of the foregoing requirements. Prior to award and payment of the grant funds as reference in this Agreement, GRANTEE shall provide DISTRICT and COUNTY evidence of such coverage.